

VEHICLE SPEED SENSOR INTERFACE – TERRATRIP / BRANTZ

Forester XT MY2004

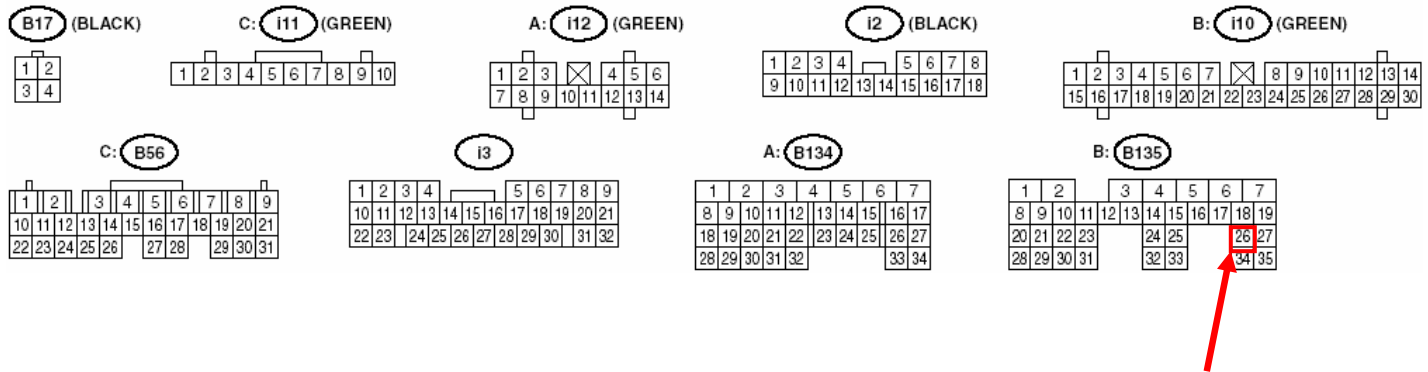
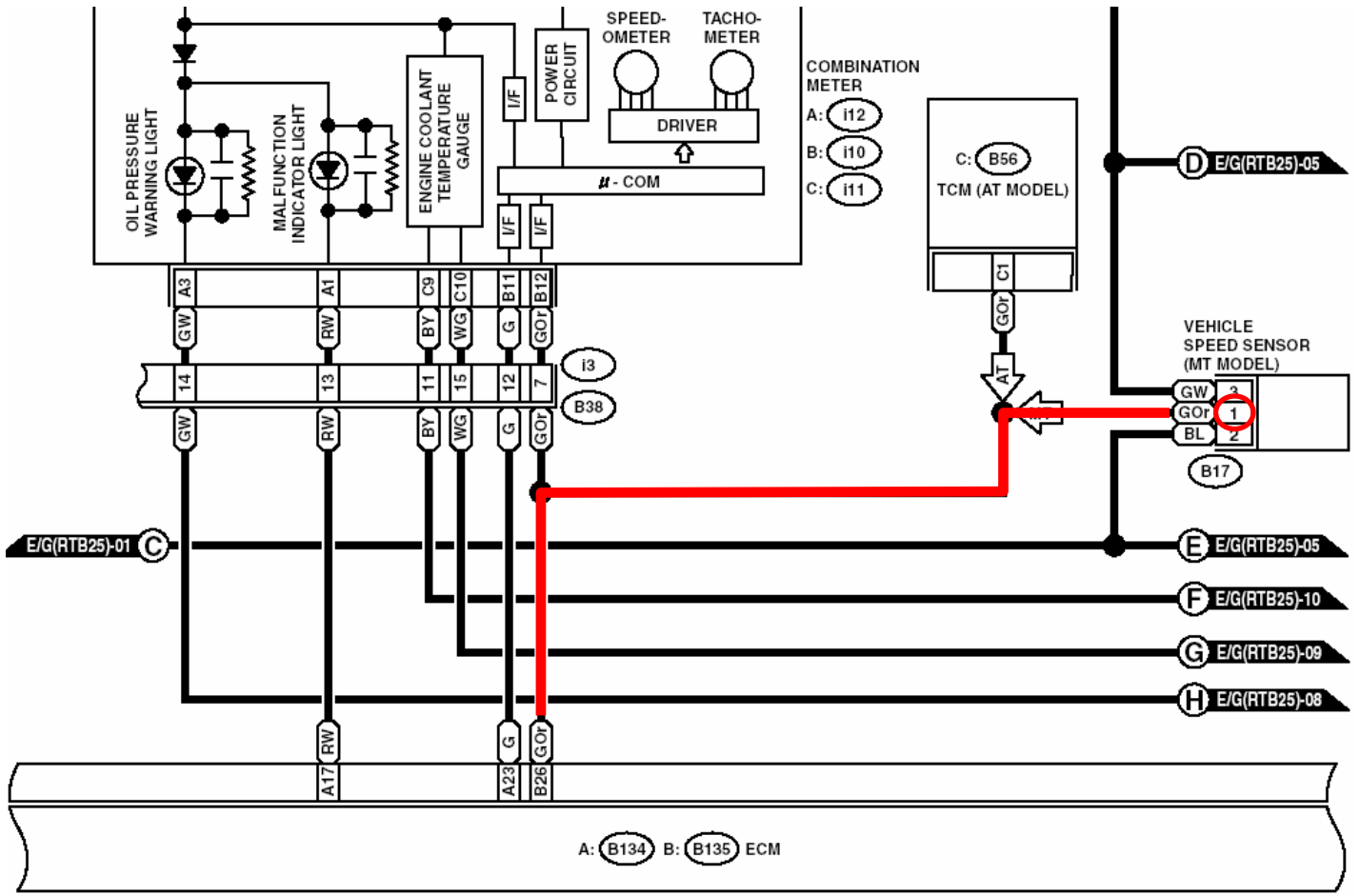

The Red wire is the speed input from speed sensor on transmission, to the instrument panel, and engine computer. You can parallel a wire from anywhere in here to give you a pulse input to the Terratrip. The red arrow points to the terminal on the ECU plug. It should be a Green Orange wire.

VEHICLE SPEED SENSOR INTERFACE – TERRATRIP / BRANTZ

Outback MY2002 and MY2003

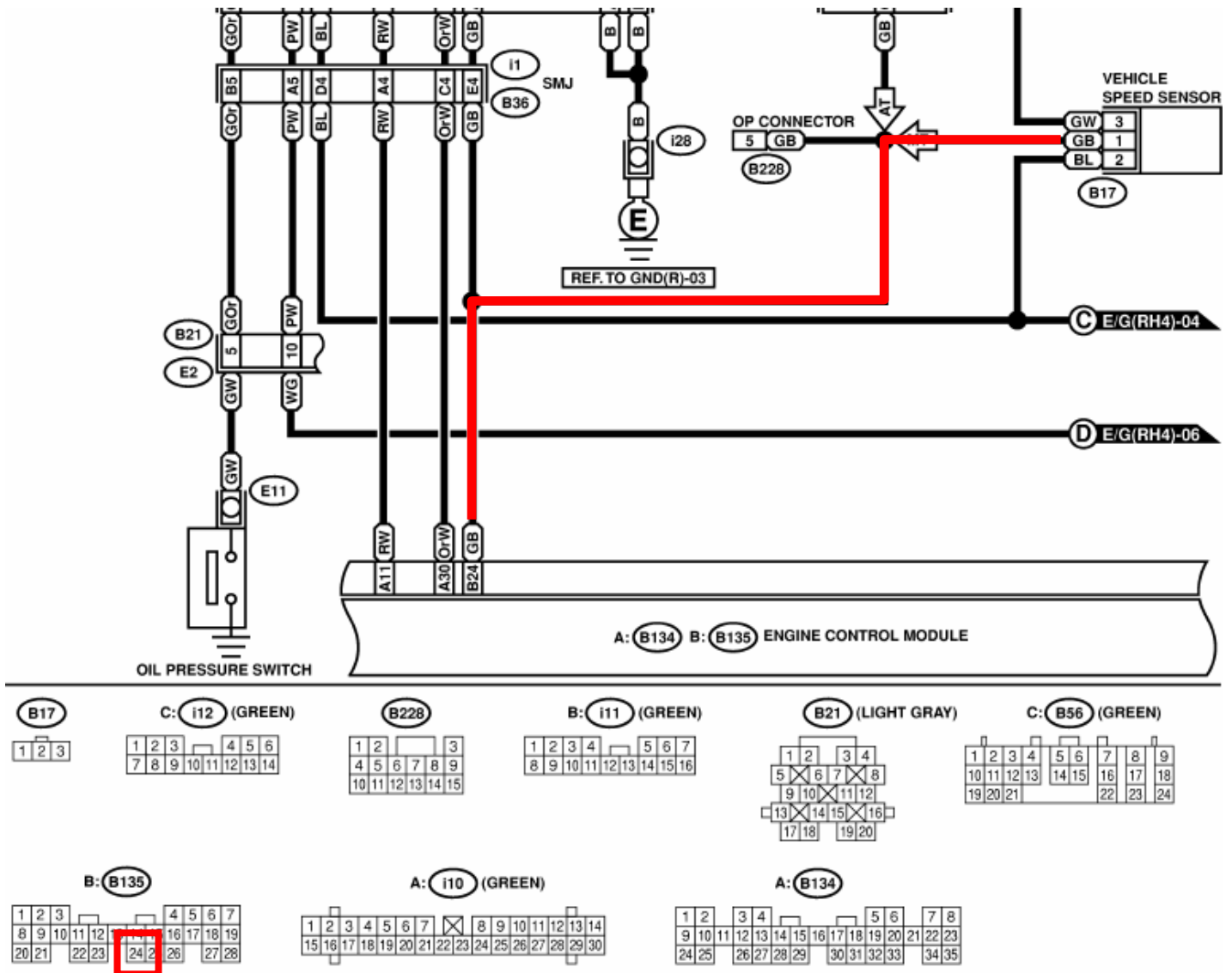

Same as above, but different connectors and terminals.
Wire colour at engine computer should be Green and Black.

Diagram above is from MY2002. Same wiring works on MY2003 vehicle.

VEHICLE SPEED SENSOR INTERFACE – TERRATRIP / BRANTZ

WRX MY1999 (Version 5)

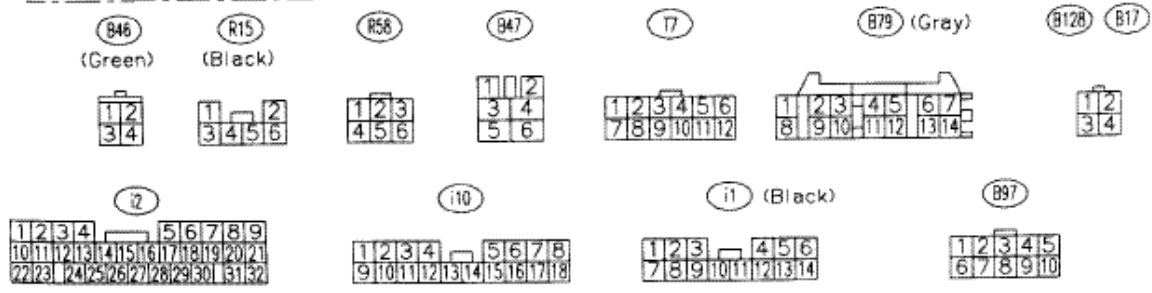
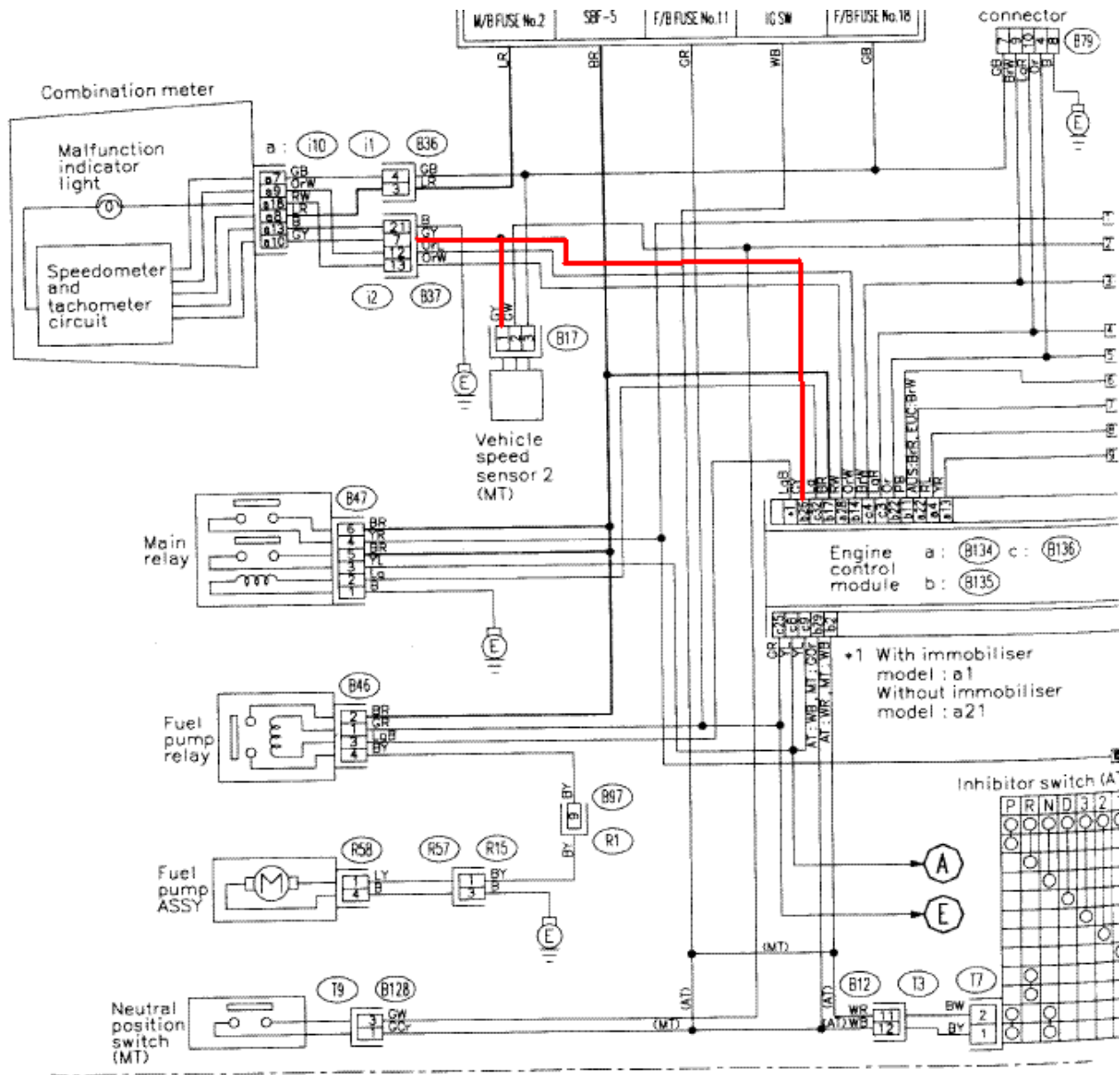

PossumLink MY99 (V5) Page 31



Green/Yellow wire on pin 26 of connector B135